

OPTICAL BEAM SMOKE DETECTOR DOP-6001

POLON 4000 and POLON 6000 INTERACTIVE FIRE DETECTION AND ALARM SYSTEM

INSTALLATION AND MAINTENANCE MANUAL

IK-E343-001GB

Edition III



The DOP-6001 beam smoke detector, covered by this manual, complies with the requirements of the following European Union directives:

CPR Regulation (EU) No 305/2011 of the European Parliament and of the Council of 9 March 2011 laying down harmonised conditions for the marketing of construction products and repealing Council Directive 89/106/EEG;

EMC The electromagnetic compatibility (EMC) Directive 2014/30/EU

LVD 2014/35/EU - on low-voltage supply electric equipment.

The CNBOP-PIB, Notified Body No. 1438 has been issued for the product the national certificate of constancy of performance confirming the possession of technical features/parameters required by EN 54-12:2015

The features/technical parameters above that exceeds the requirements of the aforementioned standards and other features/parameters specified in this manual that are not specified in the mentioned standards are confirmed by the Manufacturer.

Declaration of Performance has been issued for the DOP-6001 beam smoke detector.

The certificate and the Declaration of Performance can be downloaded from www.polon-alfa.pl

Read the manual carefully before the detector assembling and commissioning. Any nonconformity with the instructions contained in the manual may be harmful or may cause violation of the law in force

The manufacturer, POLON-ALFA shall not bear responsibility for any harms resulted from the unit application discordantly to the requirements of this instruction.



A waste product, unsuitable for further use, shall be passed to a waste electric and electronic equipment collection point.



NOTE: The manufacturer reserves the right to change product specifications at any time without prior notice.

Table of contents

1. PURPOSE	4
2. TECHNICAL SPECIFICATIONS.....	4
3. PRINCIPLE OF OPERATION.....	5
4. DESIGN.....	6
5. INSTALLATION.....	6
6. OPERATING CONDITIONS AND MAINTENANCE.....	8
7. SAFETY CONDITIONS.....	8
7.1 Repairs and maintenance.....	8
7.2 Works at height.....	8
7.3 Anti-dusting eye protection.....	8
7.4 Eye protection against laser beam operating equipment.....	8
8. STORAGE AND TRANSPORT.....	9
9. DESIGN RECOMMENDATIONS.....	9

1 PURPOSE

The DOP-6001 Beam Smoke Detector is designed for smoke detection at the start of a fire. It is especially suitable for protection of premises where, in the first phase of the fire, smoke appearance is expected and in which, due to a large space area, installation of a greater number of spot smoke detectors would be necessary. Beam smoke detectors (in comparison with spot smoke detectors) are sensitive to medium smoke density value on a long path of the infrared radiation beam and therefore they are especially suitable for application under high ceilings/roofs or in those places where smoke can be diffused over a large area before detection.

Exemplary objects especially suitable for this type detector installation are: churches, cathedrals, monumental buildings with valuable historic ceilings, theatres, sports halls, industrial shops, very high rooms, in which spot detectors would be ineffective, and rooms with differentiated ceiling or roof design. A distinctive feature of the DOP-6001 detector is its arrangement of a transmitter and a receiver in one enclosure and interaction with a prism reflector or a reflector panel placed on the opposite wall. A single casing embraces a laser target viewfinder that enables optical path axis alignment between the detector and the reflector/reflector panel.

The DOP-6001 beam smoke detector is intended for installation in the POLON 4000 and POLON 6000 fire detection systems and alarm control panel lines. The detector operates in closed premises at ambient temperatures ranging from -25 °C to $+55\text{ °C}$ and relative humidity up to 95 % at 40 °C .

2 TECHNICAL SPECIFICATIONS

Operating voltage in a detection line	16.5 V ÷ 24.6 V
Max. current consumption in detection line	< 300 μ A
Detector address and sensitivity thresholds	programmable at control panel
Detector operating voltage in a conventional line	10.5 V ÷ 24.0 V
Quiescent current in a conventional line	5 mA or 2.2 mA depending on system
Alarm current at 20 V	20 mA
Current at light beam break	< 0.3 mA
Current at service signal – optics soiling	< 0.3 mA
Sensitivity thresholds (to be chosen)	18 %; 30 %; 50 %
Operating distance	
- with E39-R8 prismatic reflector (Fig. 6)	from 5 m to 50 m
- with 4xE39-R8 reflector panel (Fig. 7)	from 50 m to 100 m
Detector angular tolerance	$\pm 0.5\text{ °}$
Reflector angular tolerance	$\pm 5\text{ °}$
Number of detectors in POLON 4000/6000 addressable line	64
Number of detectors in one conventional line	1
Power supply of laser viewfinder (during alignment)	6F22 (9 V) battery
Operating temperature range	-25 °C ÷ $+55\text{ °C}$
Admissible ambient relative humidity	up to 95 % at $+40\text{ °C}$
Ingress protection	IP40
Dimensions	129 x 80 x 84 mm
Mass (together with adjustment basis)	0.35 kg
Casing colour	white (other on request)
Suitability in test fire detection	TF1, TF2, TF3, TF4, TF5, TF7, TF8

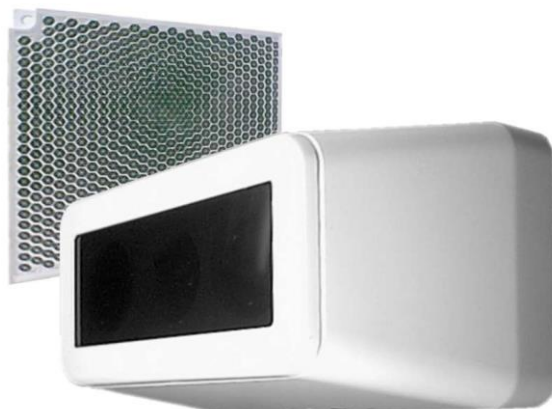

Fig. 1 DOP-6001 detector with prism reflector

3 PRINCIPLE OF OPERATION

The DOP-6001 detector consists of an infrared (IR) light transmitter and a receiver located in a single enclosure, and an interoperating separate E39-8R prism reflector or 4xE39-8R reflector panel. The detector principle of operation consists in continuous analysis of optical air transparency in a space between the detector and the reflector (reflector panel).

The detector can be in one of four modes: supervision, alarm, fault – light beam break, and fault – caused by contamination. If a certain, defined quantity of aerosol (smoke) is found in the air, reducing optical transparency below a set threshold, then the detector enters an alarm mode. Complete interruption of the radiation beam (or its reflection due to an object occurrence in its optical path) is signalled as a fault, because even the largest smoke concentration in the air does not cause an entire break of the detector optical path. When the air is clear, the detector is in supervision mode.

Long lasting detector operation, especially in high dust level premises, may lead to contamination (dust build-up) of optical parts of the detector and the reflector/reflector panel. In order to maintain constant sensitivity and fire detection ability during a long time period, the detector is equipped with automatic compensation circuits to monitor its contamination and environ impact conditions. The circuits ensure the same sensitivity threshold in the whole compensation range. At a certain contamination level, the detector signals a fault mode denoting a necessity to undertake servicing and cleaning works. However, even in this mode, the detector is still able to detect smoke and initiate an alarm. A contamination caused fault requires cleaning works of the reflector/reflector panel and the detector front surface. After cleaning, the detector adjusts to new external conditions and automatically changes its mode from fault to supervision.

Communication between the POLON 4000/6000 system control panel and the DOP-6001 detectors is provided using a two-wire detection line. A unique, fully digital communication protocol enables transmission of any information from the control panel to the detector and vice versa, such as: surrounding conditions evaluation (smokiness, temperature), their change tendency and the current analogue value of temperature and smokiness density.

The DOP-6001 addressable smoke detector is equipped with an internal short circuit isolator, which cuts off the efficient detection line from a shorted section, what enables the detector further unfailing operation.

Analysis function in the DOP-6001 detector is fulfilled by a microprocessor. After the detector optical path alignment and initiation the analysis process at the control panel level (detectors in an addressable line), or pressing the START push button (detectors in a conventional line), microprocessor circuits analyses the

ambient temperature and the settled sensitivity threshold. A self-adjustment program is switched on after entering these data into the detector memory. The self-adjustment process terminates after achieving a reference value with $\pm 5\%$ tolerance. Afterwards, the decision criteria are drawn up for various fire phenomena runs, for instance for fast or slow fire development. The data are kept in the detector non-volatile memory and periodically checked. Any measured value change (against the assumed decision thresholds) caused by a smoke, after triple verification, is treated by the microprocessor as a fire.

4 DESIGN

The DOP-6001 detector design is shown on Fig. 1 and Fig. 3. The detector casing, made of plastic, embraces electronic circuits and optical elements of a transmitter and a receiver as well as a laser diode that facilitates the detector easy optical alignment. The lenses for infrared beam focusing are covered with a detachable filter. On the detector back side a connecting block is mounted, to connect power supply wires. The detector is fastened to the wall with a metal adjustment basis. On the detector front part, illuminating diodes are placed as well as the START push button that initiates the detector adjustment process.

The illuminating diode colour signals accordingly:

- green one – a state of the detector self-adjustment to the detector-reflector/reflector panel distance, when the signal level is too high;
- yellow one – a state of the detector self-adjustment to the detector-reflector/reflector panel distance, when signal level is too low;
- red one – an alarm mode;
- no light – a supervision mode after proper adjustment of the detector with the reflector/reflector panel.

The START push button enables initiation of the detector adjustment process (self-adjustment) and the detector parameters renewed set-up after optical parts cleaning works.

5 INSTALLATION

The DOP-6001 detector interoperates with a reflector panel and then its operating distance ranges from 50 m to 100 m, or with an E39-R8 prism reflector at the operating distance between 5 m and 50 m. It is possible to install up to 64 DOP-6001 detectors in one POLON 4000 and POLON 6000 systems addressable line.

The reflector or the reflector panel as well as the M42-00 00 00 service kit, containing test foils and an adjustment mirror, are not included in the detector standard pack and should be ordered separately.

Up to 64 DOP-6001 detectors can be installed in one addressable detection line of the POLON 4000 and POLON 6000 systems. Only one DOP-6001 detector without end-of-line resistors can be installed in one conventional line.

In case the detector is seen with difficulty or is installed in a hardly accessible place, it is possible to connect the WZ-31 additional operation indicator to be placed in a convenient and visible place.

Before installation, it is necessary to declare an alarm mode and a sensitivity threshold. The operations are executed using appropriate jumpers placed on the back side of the detector casing, pursuant to Fig. 6. One of the criteria taken into consideration when choosing sensitivity may be the distance between the detector and the reflector/reflector panel, and so:

- for a distance from 5 m to 20 m – 18 % sensitivity is recommended;
- for a distance from 20 m to 50 m – 30 % sensitivity is recommended;
- for a distance from 50 m to 100 m – 50 % sensitivity is recommended.

It is possible to set sensitivity level experimentally: adopting it to a certain environment in the case of the detector difficult operating conditions. The DOP-6001 detector and the reflector/reflector panel are mounted on opposite walls, pillars or other construction elements of the premises. The walls or pillars must be stable and vibration-free. The detector adjustment basis should be mounted on a wall and the reflector/reflector panel - on the opposite wall. The detector should be placed on the adjustment basis (Fig. 3) after preliminary connection of the wires to the connecting blocks in accordance with Fig. 4. The detector should be fixed to the basis with three screws that are accessible from the front side (after removing the cover). Then a 6F22 battery should be connected to the laser viewfinder contacts.

Before alignment, the mirror (part of the service kit) should be placed on the reflector panel and press down, as it is shown on Fig. 9. With the help of three positioning screws, the detector laser beam should be aimed at the centre of the reflector or the mirror from the service kit. The adjustment screws help in precise alignment so that the laser beam returns to the detector front plate after being reflected from the reflector. The mirror should be removed after proper regulation of the optical path between the detector and the reflector. The prism reflector position cannot be adjusted and it is recommended to fix it to a flat substrate with screws or glue.

The detector is properly aligned with the reflector/reflector panel when the reflected laser light illuminates the detector. In such the situation the external battery should be disconnected, the detector cover should be mounted and the START push button should be pressed. As a result, one of the diodes: yellow or green shall be lit in a pulse manner. After ca. 40 sec. the diodes should switch off, what stands for a proper adjustment of the infrared beam to the distance between the detector and the reflector/reflector panel. During this adjustment process, the detector, being connected to a control panel, signals a fault mode. After pressing the START push button and adjusting the distance between the detector and reflector/reflector panel, the detector enters a supervision mode.

Note:

The detectors should not be exposed to direct sunlight operation.

The detector/reflector alignment with a help of a laser beam should be carried out in a dark room.



Fig. 2 DOP-6001 detector during optical path alignment

6 OPERATING CONDITIONS AND MAINTENANCE

The DOP-6001 smoke detector long-lasting operation, especially in dusty premises, may result in contamination (dust, dirt accumulation) of the optical part of the detector and of the reflector/reflector panel. After exceeding a program determined contamination compensation range, the detector transmits a fault signal to the control indicating the necessity to call a maintenance technician. The detector is still able to detect fire threat and enter an alarm mode. The contamination caused fault notification entails cleaning of the reflector/ reflector panel and the detector front plate. After cleaning the above mentioned elements, the START push button (located inside the detector) should be pressed in order to adjust the detector to new external conditions. After the adjustment, the detector automatically alters its mode from a fault to a supervision one.

It is possible to check proper operation of the DOP-6001 detectors installed in fire detecting systems during their maintenance inspection by concealing partly the detectors optical path. It can be carried out using a special damping plastic foil with overprints appropriate to the detector three sensitivity levels – 18%; 30%; 50% (Fig. 10). A plastic sheet with overprint consistent with the detector set sensitivity level should be put on the detector front plate, what should trigger an alarm mode. The DOP-6001 detector testing foil with overprints is included in the service kit.

During renovation or painting works carried out in the premises where detectors are installed, the detector and reflector/ reflector panel should be taken out. Detectors which are damaged in the time of painting and renovation works due to a fault of persons, who execute them, are not subject to warranty repairs.

7 SAFETY CONDITIONS

7.1 Repairs and maintenance

Any maintenance works or periodic inspection shall be executed by skilled personnel employed by companies being authorised or trained by POLON-ALFA. Any repairs must be carried out by the manufacturer. POLON-ALFA bears no responsibility for the operation of any apparatus being serviced and repaired by unauthorised personnel.

7.2 Works at height

Any detector installation works carried out at height must be executed with particular care utilising tools and machinery in good working condition. Special attention shall be given to the stability of ladders, platforms, etc. Any electric tool shall be used strictly obeying the safety rules specified in the manufacturer instruction manuals.

7.3 Anti-dusting eye protection

It is obligatory to use protective anti-dusting glasses and masks during detector installation works that produce high amount of dust, such as hole drilling for detector base mounting on ceilings/walls.

7.4 Eye protection against laser beam operating equipment

During the alignment of the detector optical path with the reflector/reflector panel using a laser viewfinder, special eye protection against direct laser exposure (3R laser equipment class) must be provided.

8 STORAGE AND TRANSPORT

The detectors should be stored in closed premises at ambient temperature ranging from 0 °C to +40 °C and relative humidity up to 80 % at +35 °C, free from volatile sulphur compounds as well as acid and alkaline vapours. The detectors should not be exposed to direct sun; heating devices should not directly influence the detectors or their packing.

The detectors transportation should be carried out in transport packing using any transport means and obeying the transport recommendations given on the packages and securing protection against possibility of mechanical damage and impact of temperatures lower than –40 °C and higher than +70 °C and relative humidity higher than 95 %.

9 DESIGN RECOMMENDATIONS

The DOP-6001 beam smoke detector operates properly, similarly to all other smoke detectors, in case it is installed at the height not exceeding 12 m. When it is mounted higher (up to 20 m), another row of detectors shall be provided at an intermediate level, with adequately larger number of detectors.

Maximum width (2D) of an area protected by one detector depends on the room height, according to the following table:

Height H	Operation radius D	Distance from ceiling	
		At gradient up to 20 °	At gradient over 20 °
Up to 6 m	6 m	0.2 m to 0.5 m	0.3 m to 0.5 m
From 6 to 12 m	6.5 m	0.3 m to 0.7 m	0.4 m to 1.0 m
Over 12 m	7 m	0.6 m to 0.9 m	0.8 m to 1.2 m

The maximum area protected by one detector in case the detector/reflector panel distance is 100 m for the ceiling height at 10 m amounts to (2D x 100 m) ca. 1300 m², so the detector can replace a dozen of spot smoke detectors.

The distance between the detector IR beam and a side wall of room should not exceed D value and between two adjacent detector beams – 2D. The distance from the IR beam to any obstacle (e.g. a wall, perpendicular to a side wall) shall not be smaller than 0.5 m.

The beam detector should constantly “see” the co-operating reflector, it is necessary to install it in such a way that its optical path is never – even temporarily – concealed by a moving object or equipment, such as cranes, hoists, etc. In the premises where people stay, the minimum installation height should amount to 2.7 m (so that outstretched upwards arms do not disturb the optical path). This limitation is not valid in the case of low, long or narrow spaces where people do not stay, e.g. cable channels, spaces above hanging ceilings, etc.

NOTE: The data listed in the table, especially the D operation radius value, which depends on a roof height come out from the calculations of the proportion of the beam detector arrangement versus spot detectors installed in a fire test chamber and comply with the data pursuant to VdS 2095:2005.

It differs from the data stated in the PKN-CEN/TS 54-14:2006 technical specification in which the D radius is the same for all heights and is equal to 7.5 m.

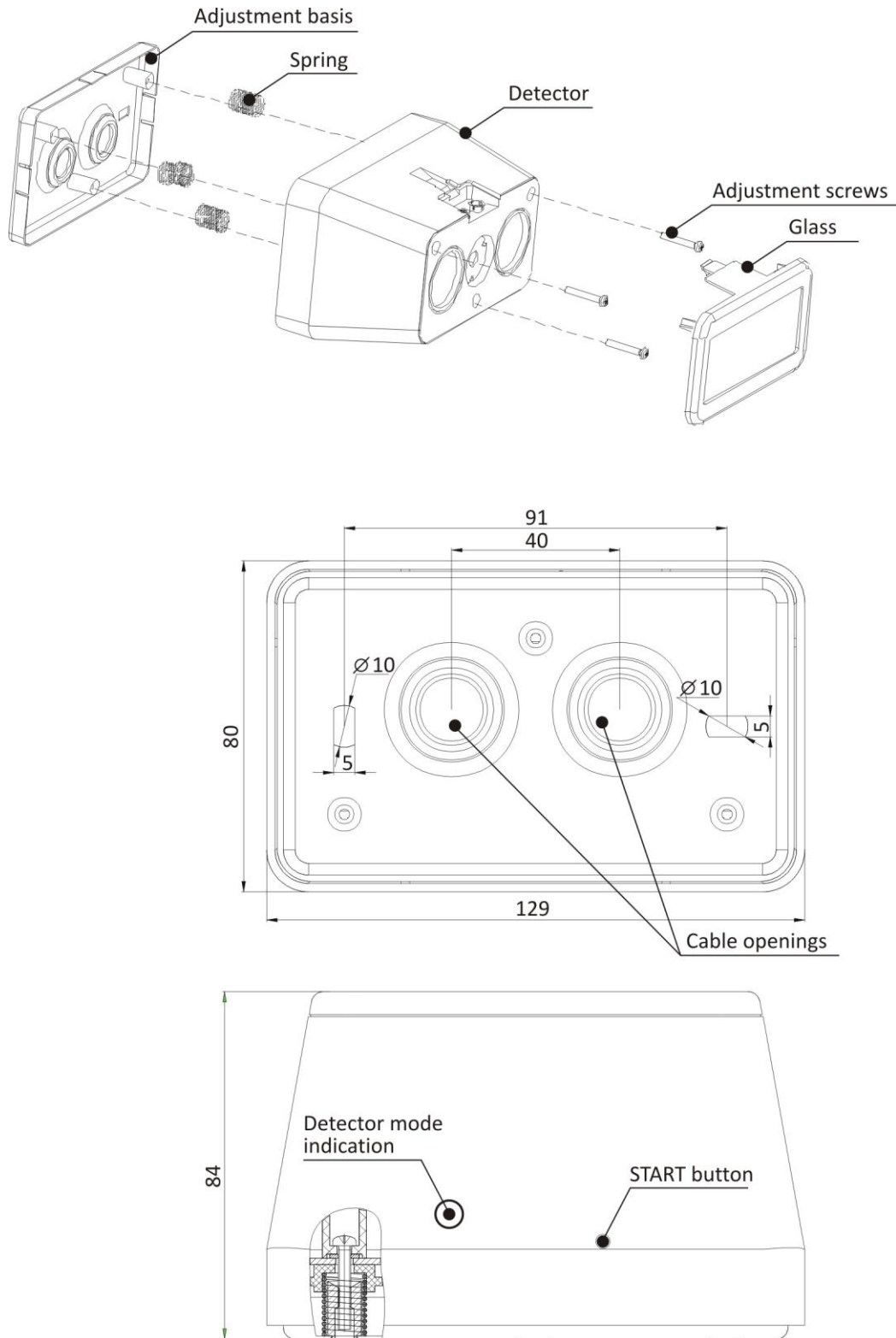

Fig. 3 DOP-6001 design and overall dimensions

Note:

Only one detector (without an end-of-line resistor) can be installed in a conventional detection line, therefore no line output to the next detector is provided.

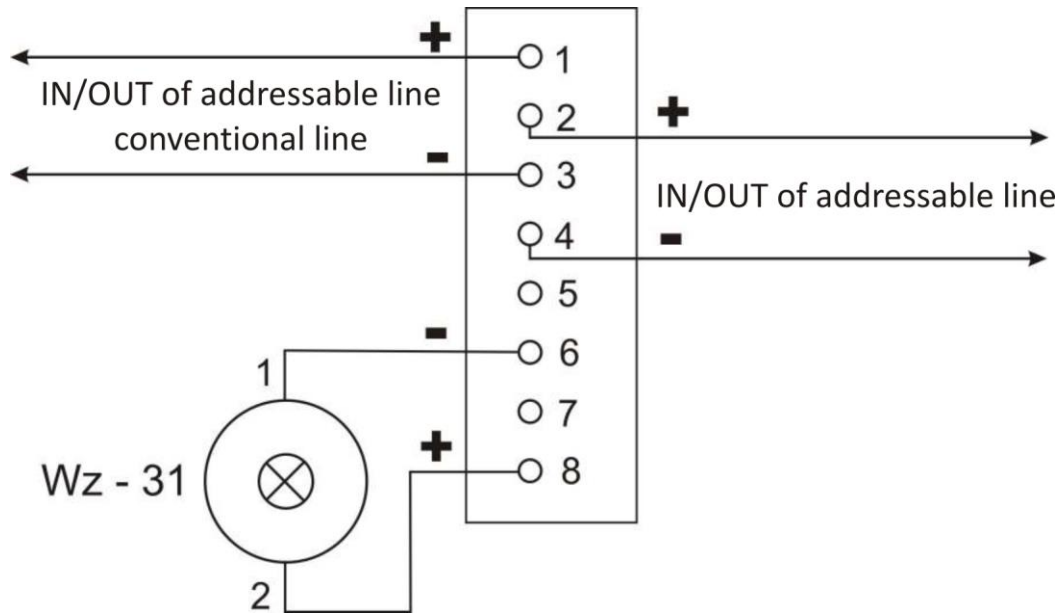

Fig. 4 DOP-6001 detector installation wires connection

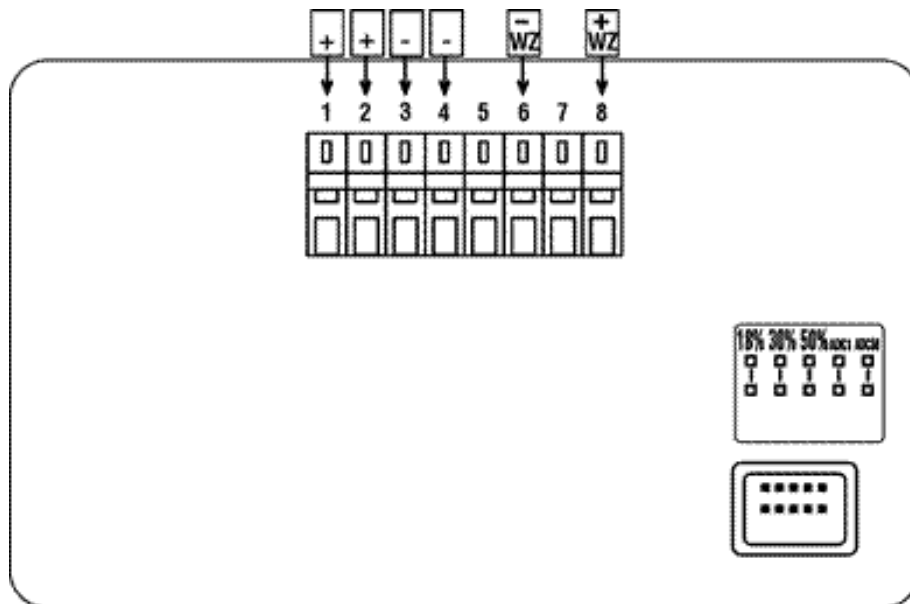

Fig. 5 DOP-6001 detector internal connections and output terminals diagram



Declared sensitivity levels:

- jumper in position 50 %
- jumper in position 30 %
- jumper in position 18 %
-

For the POLON 4000 and POLON 6000 addressable systems, the sensitivity threshold is declared in the control panel and all jumpers must be removed.

Interoperating line declaration:

- no jumper
- jumper in ADC38, ADC1 position
- POLON 4000 system addressable line
- IGNIS 1000 system conventional line.

Fig. 6 Jumpers for detector operation declaration

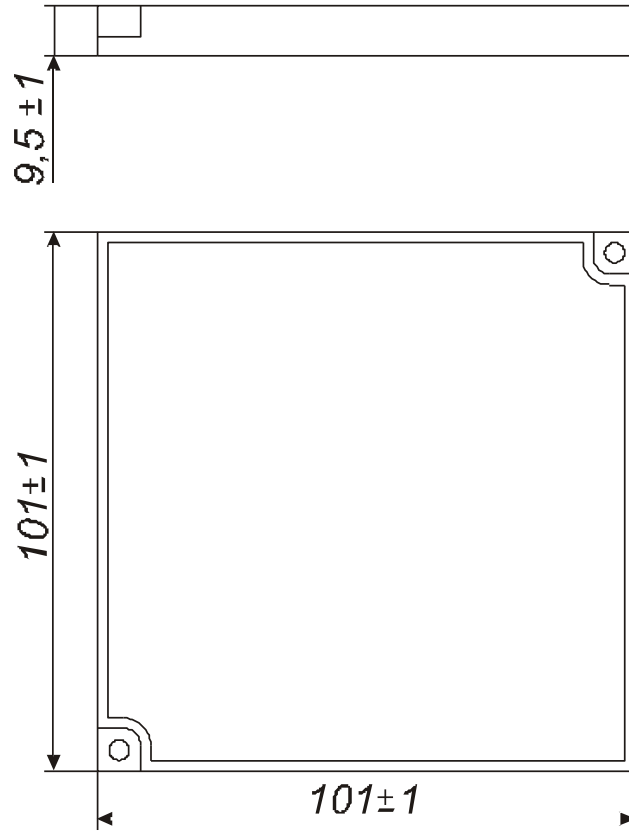

Fig. 7 E39-R8 prism reflector

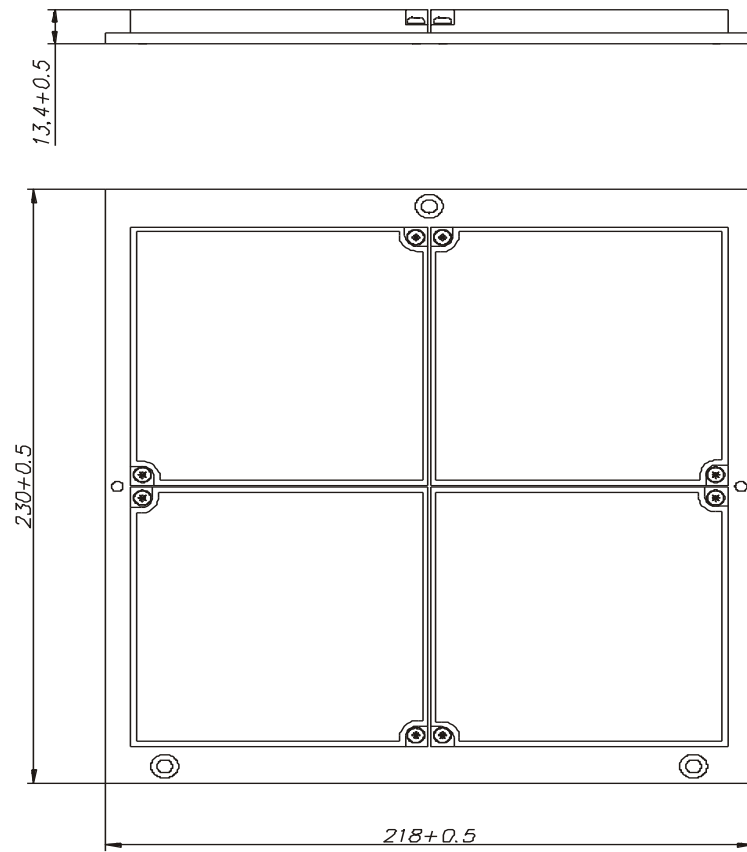

Fig. 8 Reflector panel

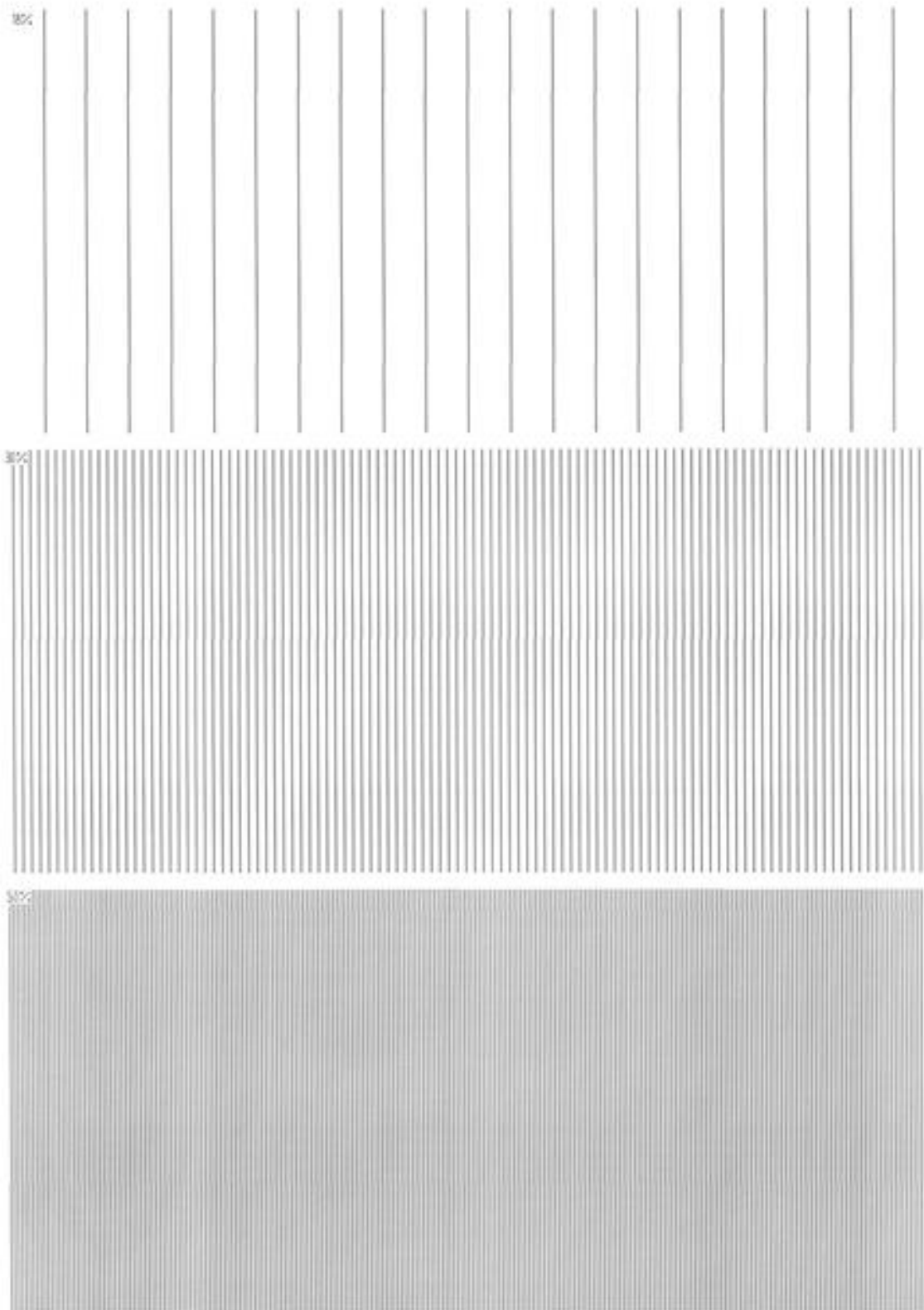

Fig. 9 DOP-6001 detector testing foil with overprints

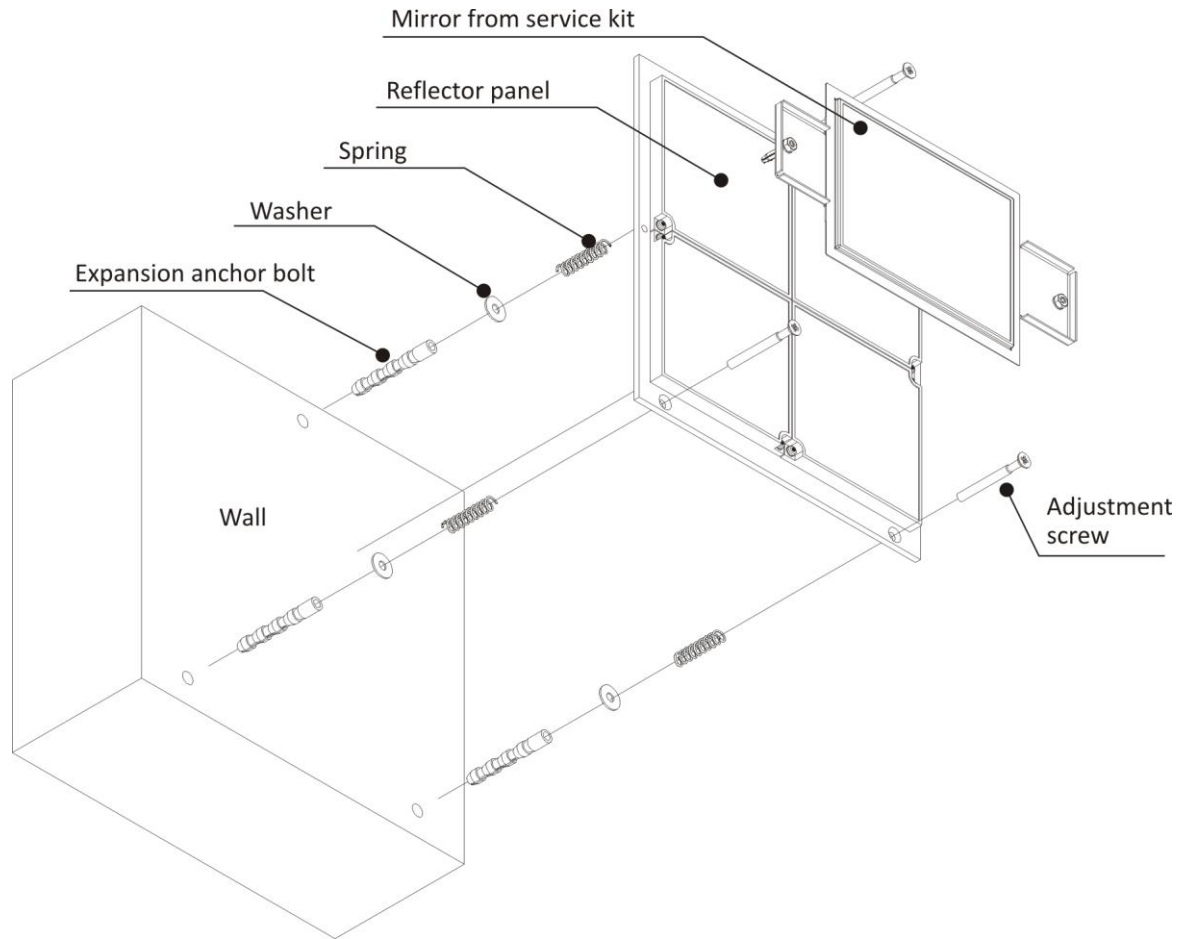

Fig. 10 Reflector panel assembly



POLON-ALFA S.A.

POLAND 85-861 Bydgoszcz, ul. Glinki 155 | www.polon-alfa.pl
EXPORT DEP. phone no. +48 52 36 39 278, email: export@polon-alfa.pl
SERVICE DEP. phone no. +48 52 36 39 390, email: serwis@polon-alfa.pl